

B80B



NEW HOLLAND BACKHOE LOADER



COMFORT AND SAFETY



A RELIABLE BACKHOE



AN EFFECTIVE LOADER



EASY MAINTENANCE ACCESS

* Optional Extendahoe

** STD GP Bucket 1m³

B80B

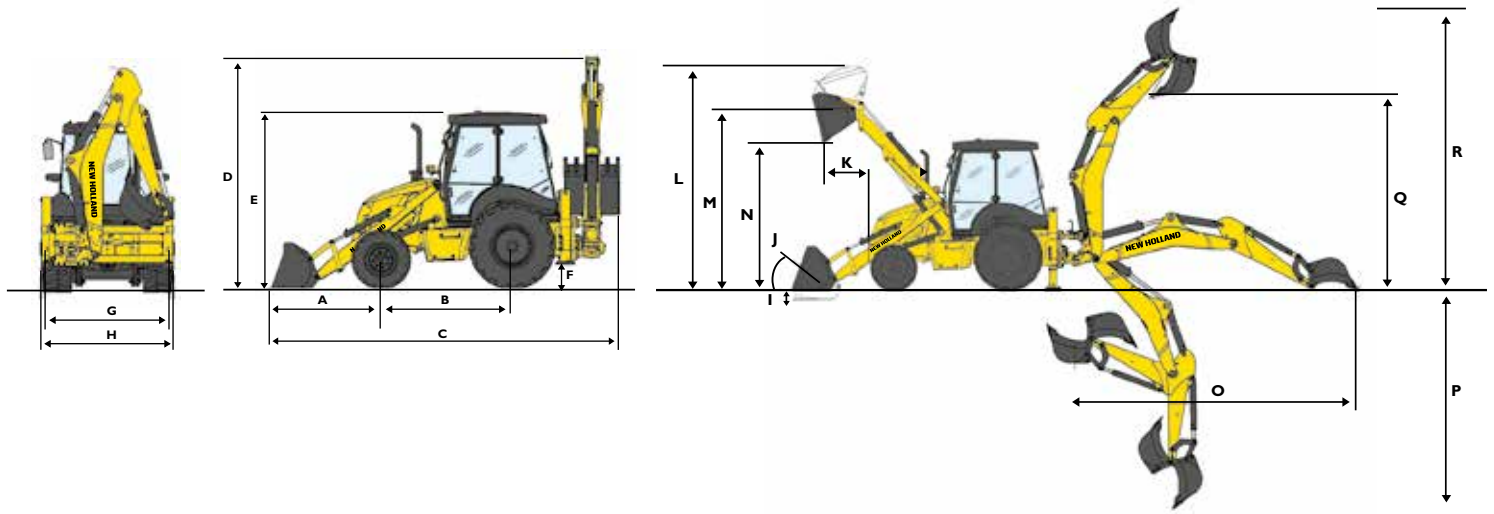

GENERAL DIMENSIONS

A	Reach at ground	mm	1980
B	Wheelbase	mm	2180
C	Overall travel length	mm	5880
D	Travel height	mm	3790
E	Cab height	mm	2870
F	Minimum ground clearance	mm	399
G	Stabilizer width	mm	2270
H	Overall width	mm	2277

LOADER DIMENSIONS

I	Digging depth (GP bucket)	mm	98
J	Roll back angle	°	36
K	Maximum reach	mm	760
L	Maximum height	mm	4190
M	Hinge pin height	mm	3580
N	Maximum dump height at 45°	mm	2720
	Maximum lift capacity at full height	Kg	3425
	Loader arm breakout force	Kgf	6314
	Loader bucket breakout force	Kgf	6250
	General purpose loader bucket	m ³	1

BACKHOE DIMENSIONS

O	Digging reach at ground level	mm	5657
P	Maximum digging depth	mm	4399
Q	Maximum dump height	mm	3644
R	Maximum digging height	mm	5489
	Dipper arm breakout force	Kgf	4370
	Bucket breakout force	Kgf	5716
	General purpose 600 mm bucket	m ³	0.14

LOADER OPTIONAL EQUIPMENT

	Multi-purpose 4 in 1 bucket
	Multi-purpose 6 in 1 bucket
	Tool carrier loader arm (Parallel lift)

BACKHOE OPTIONAL EQUIPMENT

	Hammer circuit
	Extendahoe

OTHER OPTIONAL EQUIPMENT

	No air conditioning option available
	Front mud guards

SPECIFICATIONS

ENGINE

Engine make	FPT 8045.45
Displacement	3.9 litre
Power output Gross (ISO 14396)	72 kW (96 hp) at 2200 rpm
Torque Gross (ISO 14396)	420 Nm at 1300 rpm
Injection	Mechanical
Emissions regulated	Tier 3

POWERTRAIN

Transmission	Carraro
Model	4WD TLBI
Type	Synchro shuttle
Forward speeds (km/h)	6 - 10 - 21 - 39
Reverse speeds (km/h)	7 - 12 - 24 - Not Rec
Front axle	Carraro 26.17 M
Rear axle	Carraro 28.32 M
Service brake	Wet disc type
Park brake	Caliper type

HYDRAULICS

Hydraulic system type	Closed centered, load sensing system
Pump type	Tandem gear pump
Maximum flow rate	151 litres/min
Maximum operating pressure	210 bar

ELECTRICAL

Starter	Bosch, 3 kW
Alternator	Bosch 65 Amp
Battery	12 volt, 130 Ah (SAE)

CABIN

Safety certifications	ROPS ISO 3471 FOBS ISO 3164
-----------------------	--------------------------------

FLUID CAPACITIES

Fuel tank	129 litres
Engine oil	9.1 litres
Coolant	24 litres
Transmission oil	20.8 litres
Axle oil	26 litres
Hydraulic oil	107 litres